

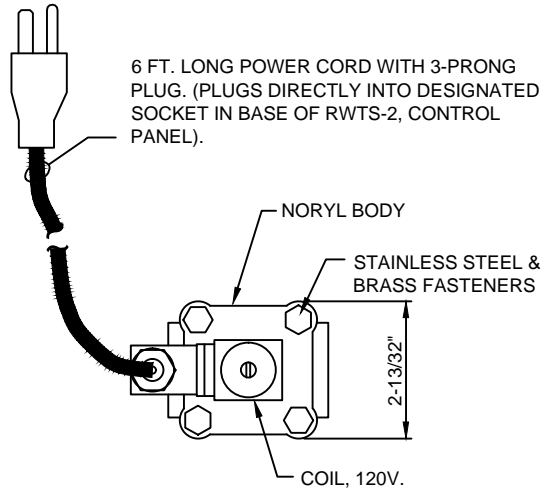

RWTSOL-075, CHEMICAL TREATMENT CONTROL VALVE

(877 794-1802)

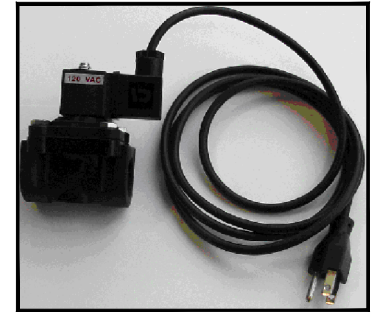

TOP VIEW

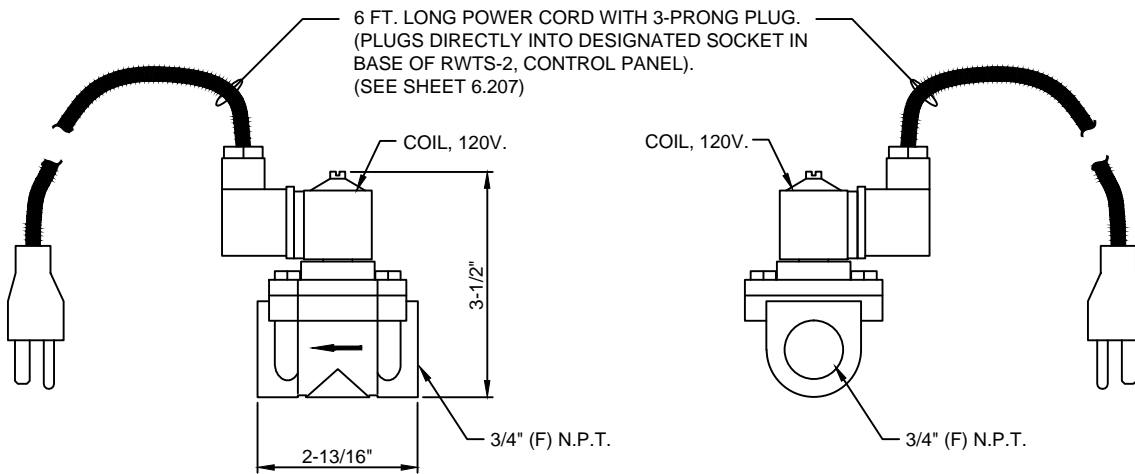

ELEVATION

END ELEVATION

SPECIFICATION DATA: 2-way solenoid valve is used in conjunction with an electronic water treatment system and is energized to provide water supply to Bromine/Chlorine erosion feeders. The solenoid body is chemical resistant Noryl GTX830 plastic with stainless steel fasteners and internal components with nitrile seals. Removable/replaceable standard Class 'A' coil operates at 120V, 50-60 Hz./5-watts. Normally-closed valve, energize-to-open. 3/4" (F) N.P.T. connections.

DRAWING NO.
6.212