

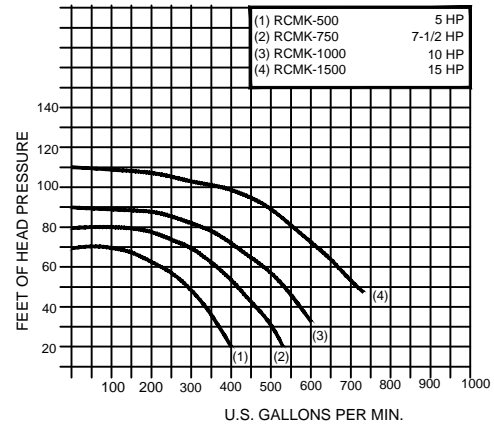

RCH/MK SERIES, LARGE CAPACITY SELF-PRIMING PUMP

(877) 794-1802

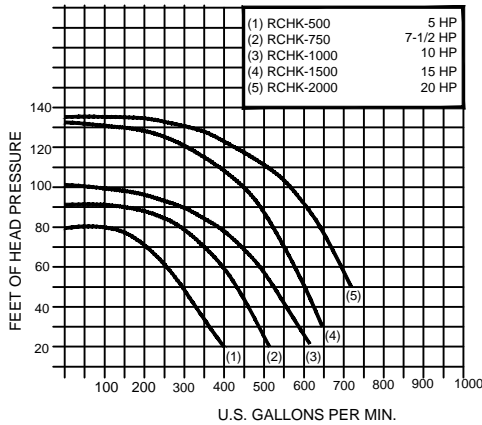
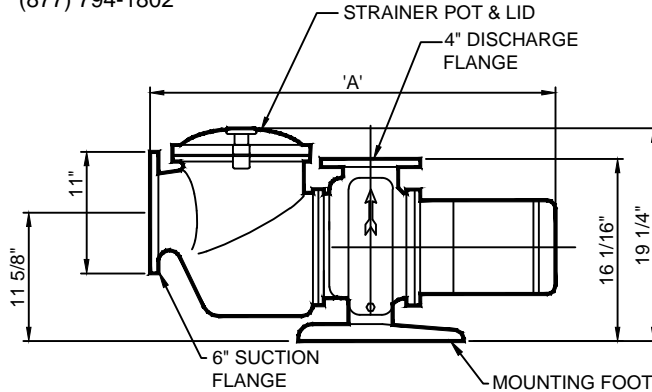

NOTE: PERFORMANCE CURVES BASED ON 3,450 RPM IMPELLER SPEED.

TECHNICAL DATA					
Model No.	HP	Power	Cycle	Phase	DIM 'A'
RCHK OR RCMK-500	5	208/220/440	60/50	1 OR 3	*
RCHK OR RCMK-750	7-1/2	208/220/440	60/50	1 OR 3	36"
RCHK OR RCMK-1000	10	208/220/440	60/50	3	37-1/4"
RCHK OR RCMK-1500	15	208/220/440	60/50	3	38-3/4"
RCHK-2000	20	208/220/440	60/50	3	42-1/2"

*RCHK OR RCMK-500: 35-1/2" SINGLE-PHASE, OR 36" FOR THREE-PHASE

SPECIFICATION DATA: Large Capacity Self-Priming Pump; Standard cast brass construction, leak-less mechanical shaft seal with carbon-ceramic face, extra close coupled design, removable stainless steel strainer basket with 1/4" openings, integral strainer pot with quick opening lid, 208/220/440 Volt, 60/50 Cycle, 1 or 3 Phase open drip proof (ODP) motor, 3,450 RPM, 1.15 service factor, A.S.A. standard 6" suction x 4" discharge flanged connections.

DESIGN/APPLICATION DATA: RCHK/CMK Series single stage, centrifugal self-priming pumps are designed for general pumping service from remote locations, and feature medium and high head models. Designed for use above or below fountain pool water level elevation, their compact design conserves pump room space.

NOTES: 1. Maximum suction lift 6 ft. above lowest pool water level; suction side of pump may require a separate check or foot valve for self-priming applications (By Installer).

2. Due to our continuing product improvement program, Roman Fountains reserves the right to change the specifications without notice.

DRAWING NO.
3.120