

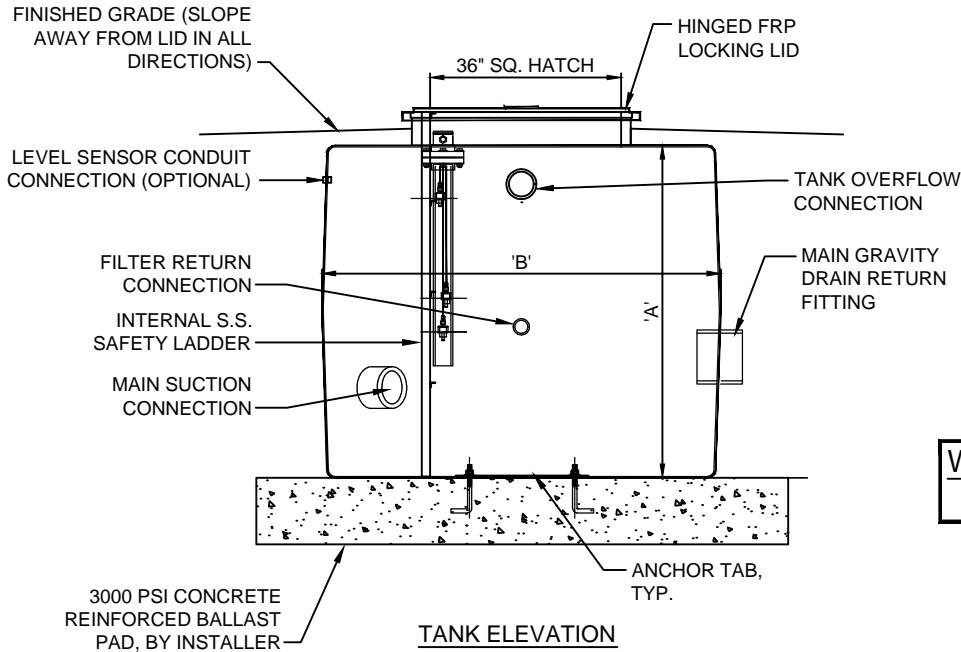

(877) 794-1802

RWST SERIES, WATER STORAGE/SURGE TANK



WARNING: FOR 'DRY HOLE' INSTALLATION ONLY.

TECHNICAL DATA				
MODEL	CAPACITY	HEIGHT 'A'	DIA. 'B'	HATCHWAY
RWST-500	500 GAL.	60"	60"	36x36
RWST-1000	1000 GAL.	72"	72"	36x36
RWST-1500	1500 GAL.	84"	72"	36x36
RWST-2000	2000 GAL.	72"	96"	36x36
RWST-3000	3000 GAL.	96"	96"	36x36

SPECIFICATION DATA: Water Storage/Surge Tank; Non-corrosive FRP or Linear Polyethylene, designed for durability and watertight storage. Unit complete with locking hatchway, internal safety ladder, and all required fittings based on project design requirements.

DESIGN/APPLICATION DATA: Roman Fountains RWST-Series, tanks are used for surge/storage applications on fountains systems where there is no traditional pool.

NOTES: 1. Other capacities available; consult factory.

2. Follow all 'OSHA' confined space procedures for maintenance & servicing of tank.

3. Do not use for drinking water, install in path of vehicles, or install in high water table areas.

4. Fitting sizes and locations shown 'typical' only. Final sizing and locations will depend on specific job requirements.

5. Electronic level sensor control available as a separate item. (Use RCOM-RNF/RNFT SERIES). Contact factory for assistance & specifications.

6. Due to continuing product improvement program, Roman Fountains reserves the right to change the specifications without notice.

DRAWING NO.
3.502