

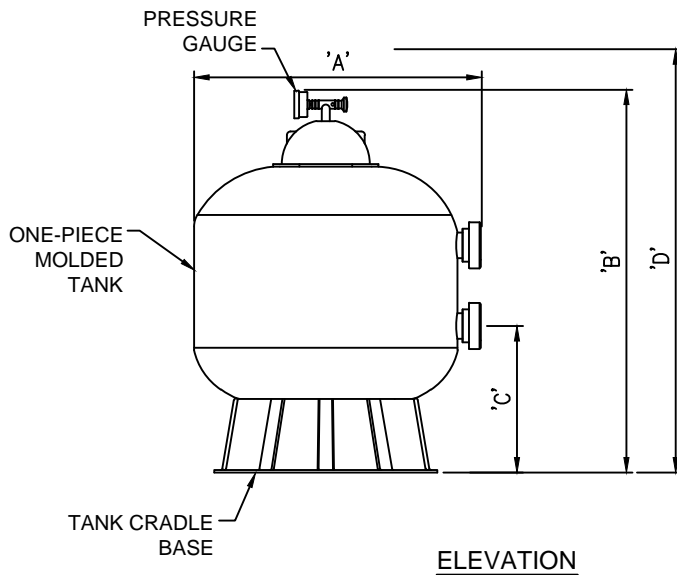

(800) 794-1801



RSFP-140,
HIGH-RATE SAND FILTER



TECHNICAL DATA								
MODEL	AREA Sq. FT.	FLOW RATE (GPM)	SAND REQUIRED (Lbs)	EMPTY TANK WEIGHT	DIM 'A'	DIM 'B'	DIM 'C'	DIM 'D'
RSFP-140	7.06	106	925	54 Lbs	36-1/2"	45-1/4"	18-3/4"	47-1/4"

* Flow Rate will vary when used for interactive features. Consult factory.

SPECIFICATION DATA: High-Rate Sand Filter; corrosion resistant, UV resistant, precision molded, one piece tank, patented water distribution system for even water flow over media bed, under-drain system with self-cleaning laterals, thermoplastic manual multi-port dial valve with built-in automatic air relief and pressure gauge. Valves sold separately. Consult factory.

DESIGN/APPLICATION DATA: Roman Fountains RSFP Series filter systems are designed for use in small to medium fountains and reflecting pools where filtration is required.

FEATURES:

- Corrosion-resistant, ultraviolet resistant, precision molded one-piece tank.
- Combination sand and water drain speeds servicing and winterizing.
- Swing-away water diffuser allows instant access to sand and all internal parts.
- All internal parts are threaded for ease of maintenance.
- Maximum Operating Pressure 50 psi

NOTE: Due to our continuing product improvement, Roman Fountains reserves the right to change the specifications without notice.

DRAWING NO.
6.103