

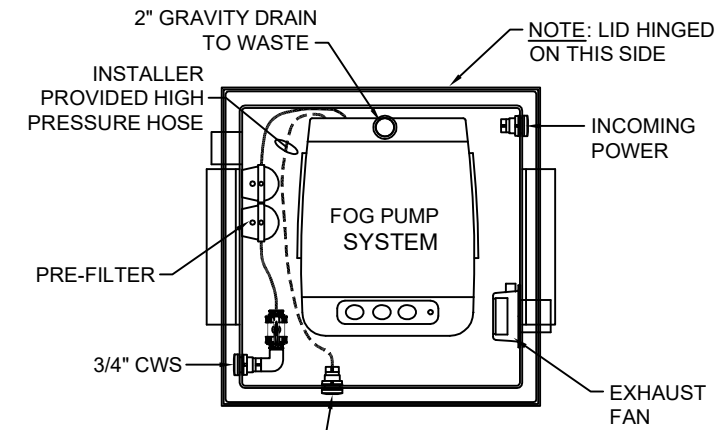

(877) 794-1802

RDP-F SERIES, FOG/MIST DIRECT BURIAL PUMP VAULT



FOG VAULT

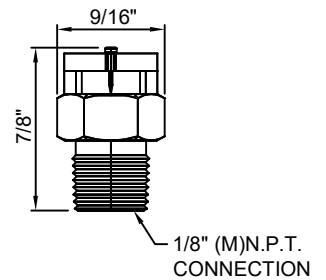
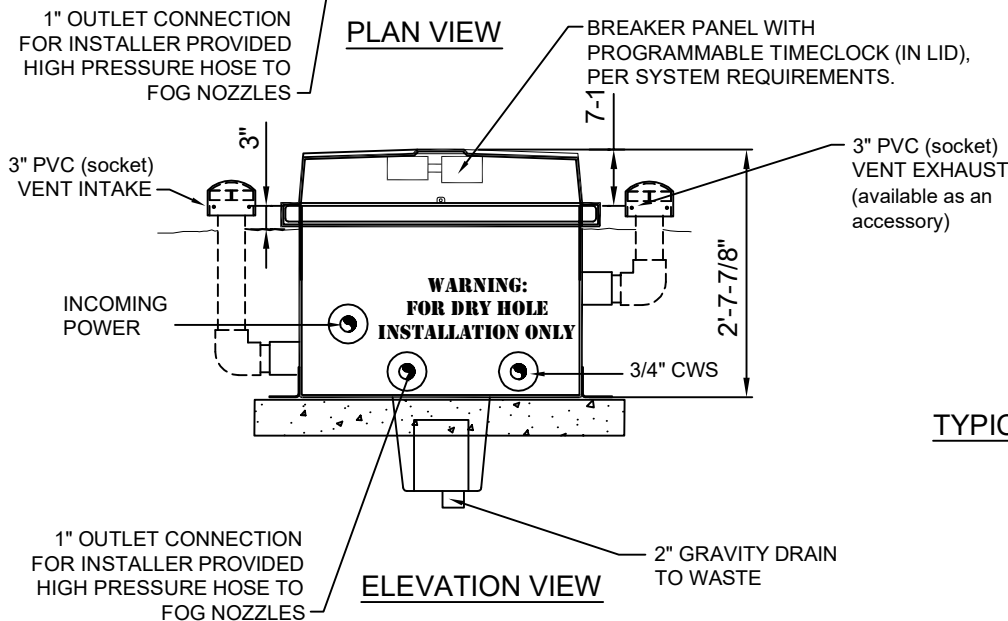

TYPICAL FOG NOZZLE (ACCESSORY)

TECHNICAL AND HYDRAULIC DATA						
MODEL	HP RATING	GPM	NOZZLE CAPACITY	PRESSURE RATING	VOLTS/ PHASE	AMP RATING
RDP-F-100	1.0	1	16-32	1000 PSI	110/1	12.6
RDP-F-100	1.0	1	16-32	1000 PSI	220/1	6.3
RDP-F-150	1.5	2	33-64	1000 PSI	110/1	15.0
RDP-F-150	1.5	2	33-64	1000 PSI	220/1	7.5
RDP-F-300	3.0	3	65-100	1000 PSI	220/1	13.5

NOTE: FOG NOZZLES AND ANY REQUIRED DISTRIBUTION MANIFOLDING WILL BE QUOTED SEPARATELY PER THE PROJECT REQUIREMENTS.

SPECIFICATION DATA:

Series I Direct Burial Pump Vault, consisting of a 3'-5" sq. x 2'-8" deep heavy duty FRP vault with white gel-coat interior and brown gel-coat exterior, furnished with fiberglass reinforced plastic lid with stainless steel piano hinge attachment and locking device, Containing a RHMP Series; Fog System, consisting of: heavy duty, pulley-driven plunger pump vented enclosure with rubber support feet, adjustable pressure regulator with bypass, liquid-filled pressure gauge, built-in solenoid valve, oil drain line, 'on-off' switch and 6 ft. connected power cord. Pump vault also includes; U.L. listed time clocks and power distribution breakers (Class A GFCI as required), 3" vent connections with 105 CFM vent fan, 2" floor drain. Unit is factory engineered, assembled and tested prior to shipment. Power requirement: 120/220V., single-phase.